

# User guide

PowerUP series generators  
UP200 | UP400 | UP1K

# Table of Contents

<b>1. Introduction</b>	<b>4</b>
1.1 Foreword	4
1.2 Safety information	5
1.3 Compliance	7
1.4 Warranty	7
<b>2. Product</b>	<b>8</b>
2.1 Overview	8
2.2 Front panel Interface	8
2.2.1 User menu	9
2.3 Specification	10
2.4 Box content	11
<b>3. Installation</b>	<b>12</b>
3.1 Tools	12
3.2 Generator installation	12
3.3 Gas system assembly	13
3.4 Gas system connection	14
3.5 Electrical connection	16
3.5.1 Generator mode	16
3.5.2 Battery Charging Mode	17
3.5.3 USB Charging Mode	17
<b>4. Operations</b>	<b>18</b>
4.1 Operating modes	18
4.2 Switching on	19
4.3 Switching off	19
4.4 Hydrogen cylinder replacement	19
4.5 Hydrogen cylinder refilling	20

<b>5. Maintenance</b>	<b>21</b>
5.1 Filters replacement	21
<b>6. Troubleshooting</b>	<b>22</b>
6.1 Errors and Troubleshooting	22
6.2 Recharging the internal battery	25
6.3 Support contact	25
<b>7. Transportation and storage</b>	<b>26</b>
7.1 Transportation requirements	26
7.2 Storage requirements	26
<b>8. End of life and disposal</b>	<b>27</b>

# 1. Introduction

## 1.1 Foreword

Thank you for choosing PowerUP Energy Technologies as your clean energy provider! Have fun with your new energy supply system.

Please read these installation instructions before using the generator. Kindly contact us if you have any questions about installing or using your generator. If you have any remaining questions about our generators, please contact us **[support@powerup-tech.com](mailto:support@powerup-tech.com)**.

## 1.2 Safety information

Before operating, read the instructions and keep them for reference. Be sure that you adhere to all manual instructions.



### **WARNING!**

- The PowerUP series generators may only be operated in a well-ventilated environment.
  - Ensure that airflow is not obstructed by any objects.
  - Keep PowerUP series generators away from flammable substances, sources of flame and sparks.
  - Do not use generator, cables or accessories if they are damaged. If they are damaged, contact support for assistance.
  - Protect generator from water ingress.
  - Unplug and power off the appliance before cleaning and maintenance.
  - Do not attempt to disassemble or repair the device.
  - Use original accessories only.
- 
- Mount the cylinders securely to mitigate possible damage from movement.
  - If a fire occurs in/around the generator or cylinder, use a CO<sub>2</sub> fire extinguisher only.

- Prevent all direct human exposure to hydrogen gas. Although it is non-toxic, it can act as an asphyxiant and can cause loss of consciousness.
- When storing or using hydrogen cylinders indoors, it is recommended to install an external, wall-mounted hydrogen alarm within that space to detect leaks. Please contact PowerUP [sales@powerup-tech.com](mailto:sales@powerup-tech.com) to procure and install such an alarm.
- Do not handle compressed hydrogen gas cylinders without training or prior experience. Contact [support@powerup-tech.com](mailto:support@powerup-tech.com) to get basic training on handling hydrogen.
- Do not transport hydrogen cylinders with a regulator attached – always disconnect the regulator prior to transport. Always use a plastic cap (as provided by the manufacturer) to protect the inlet valve of the cylinder.

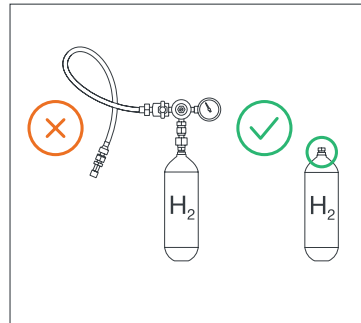

## 1.3 Compliance

PowerUP series generators are compliant with:

- EU WEEE Directive (2012/19/EU)
- EU RoHS Directive (2011/65/EU)
- 2014/30/EC The Electromagnetic Compatibility Directive
- 2014/95/EU General Product Safety Directive
- EN 61000-6-2:2005 Electromagnetic compatibility (EMC) – Generic standards – Immunity for industrial environments
- EN 61000-6-4:2007+A1:2011

## 1.4 Warranty

Your warranty begins upon the purchase of your new product.

You may use your receipt, invoice, or other evidence of purchase as a record of the time and date. You should safely store these papers. Our warranty services are based on the current *Powerup warranty terms and conditions*.

Email: [support@powerup-tech.com](mailto:support@powerup-tech.com)

# 2. Product

## 2.1 Overview

UP series generators are fuel cell based devices that convert chemical energy stored in hydrogen fuel to electrical energy. The generators are designed to be lightweight, reliable and easy to use. The only byproducts of the generator are water and heat. The generators have easy to use electrical and gas connections and an intuitive control panel.

## 2.2 Front panel Interface

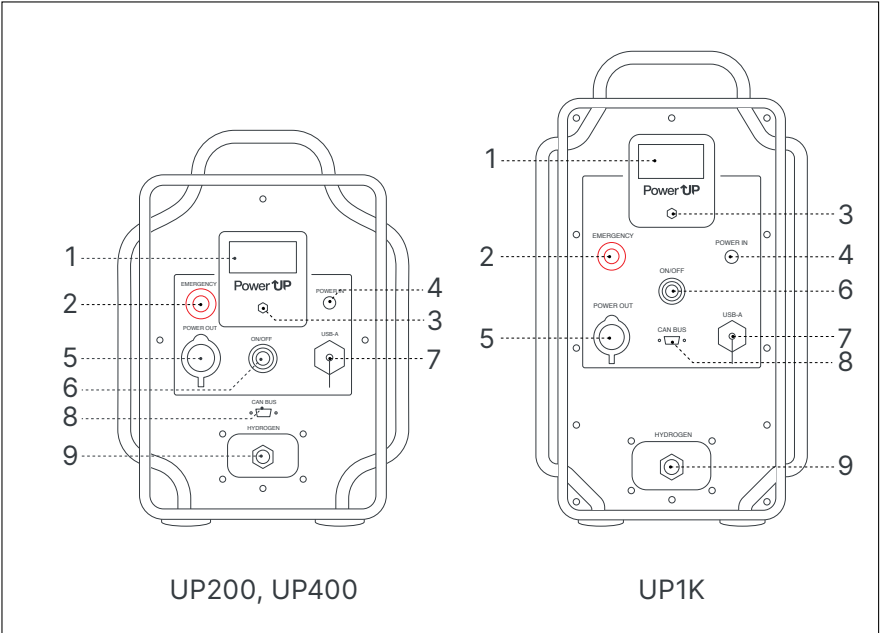



1. **Monochrome display**  
(see detailed description in 2.2.1)
2. **Emergency OFF** Button
3. **Clickable Rotary Encoder**  
Used to navigate through the menu
4. **DC In**  
14V, 6.5mmOD, 4.4mmID
5. **DC Out**  
3-pin, 12V/24V Selectable
6. **ON/OFF** Button
7. **USB Port**, Type A 5V, 500mA
8. **CAN Bus**, D-SUB Female
9. **Hydrogen Inlet**

## 2.2.1 User menu

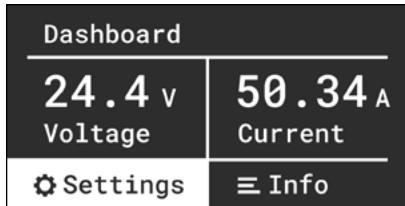

1. **Voltage output**
2. **Current output**
3. **Settings**  
In this menu point, you can change the voltage output to be 12V/24V
4. **Info**  
Additional operational parameters

## 2.3 Specification

Parameter/Product	UP200	UP400	UP1K
Fuel Cell Technology	PEM (proton-exchange membrane) Fuel Cell		
Cooling Type	Forced Air		
Unit Type	Stand alone		
Nominal Power Output, W	200	400	1000
Nominal Current, A	17	33	42
Nominal Output Voltage, V DC	12 /24 selectable		
Max Output Voltage, V DC	26 (in battery charging mode)		
<b>Dimensions</b>			
l, mm	700		
w, mm	222		
h, mm	284	312	410
Weight, kg	12	16	25
IP Rating	IP44		
H2 Fuel Purity Requirement, %	% ≥99.95		
H2 Supply Pressure, barg	0.36...0.56		
Startup time, min	≤2		
Shutdown time, min	≤2		
Operating ambient temperature, °C	-5...40		
Operating Ambient Humidity, %	0 to 100 RH non-condensing		
Operating altitude above sea level, m	2000		
Operational life, Hours	10000		
Storage Ambient Temperature, °C	-5 to +30		
Storage Ambient Humidity, %	30 to 70 RH		

# 2.4 Box content

- (1) UP Generator (UP200/400/1K)
- (2) DC Output Cable
- (3) Battery Charger
- (4) Gas System

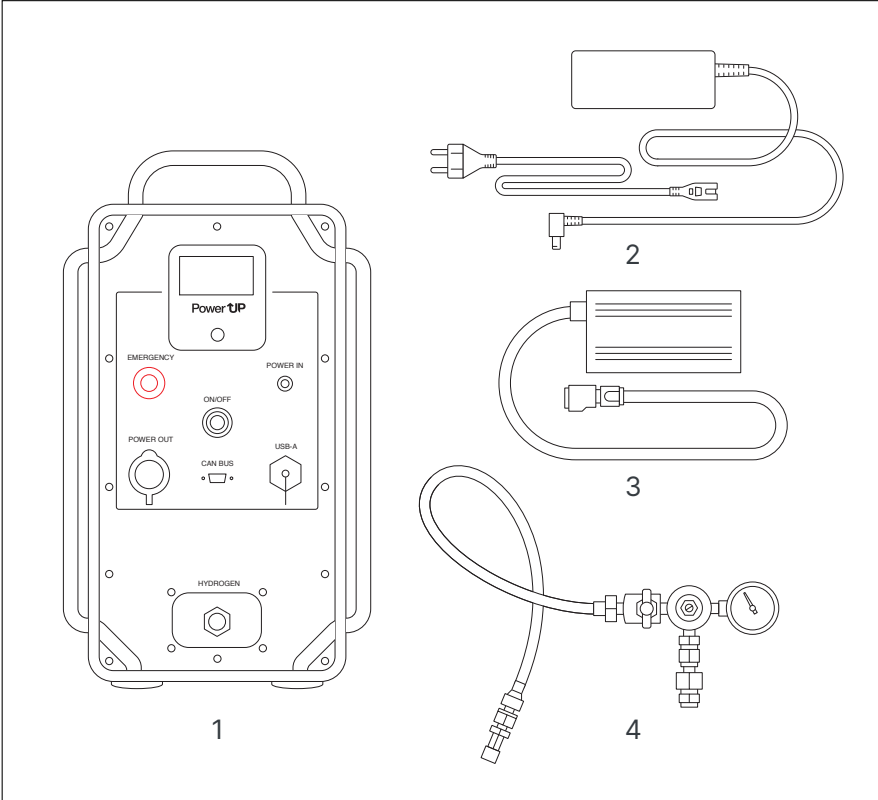

# 3. Installation

## 3.1 Tools

Generator Installation does not require any tools.

Standard gas system assembly requirements:

- 2 pieces of 28 mm Wrenches
- M2.5 hex screwdriver

## 3.2 Generator installation

- UP series generators require oxygen from air for their operation, therefore generators shall be installed in the spaces with an adequate air flow.
- When generators are installed in confined compartments, additional vents might be required to provide sufficient air flow.
- Allowed spatial orientation.
- A minimum 5 cm of clearance is required between side air vents and the wall.

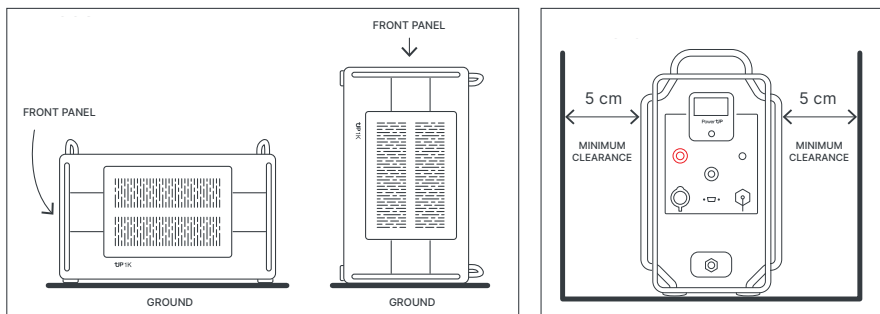

- Avoid installing generators in direct sunlight.

### 3.3 Gas system assembly

*Only applicable if the gas system is supplied by PowerUP or its official partners.*

To connect the regulator to the cylinder, two (2) number 28 wrenches are required. Please follow these instructions.

1. Inspect cylinder(s), regulator, hose and quick connector for any physical damage.
2. Ensure threads and quick connectors are clean and undamaged.
3. Ensure the valve is in the closed position.
4. Place one of the wrenches around the valve on the top of the cylinder to prevent it from moving.
5. Place the regulator on top of the cylinder, and hand-tighten the brass nut in a counterclockwise motion.
6. Use the second wrench to tighten the brass nut.
7. Inspect the gas system for leakage (refer to 4.4).

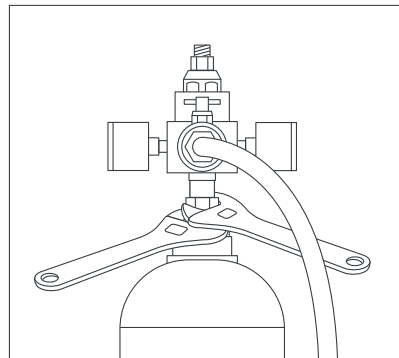
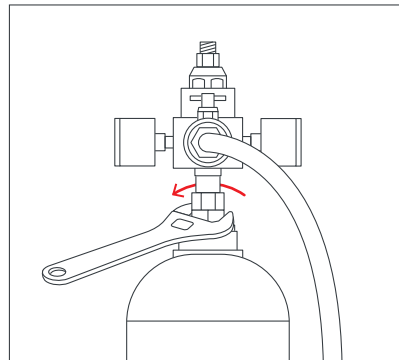
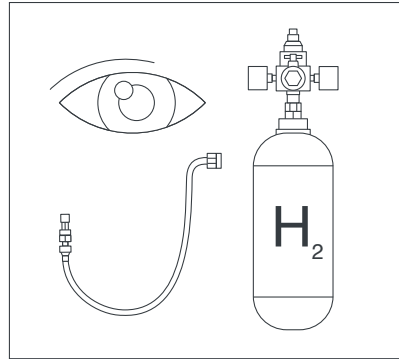

## 3.4 Gas system connection

1. Connect the connector-end of the hydrogen hose on the regulator assembly to the 'Hydrogen Inlet' port of the generator.

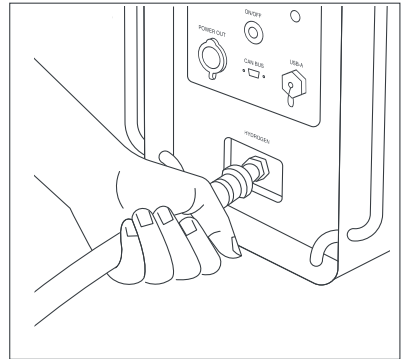

2. Push the connector onto the 'Hydrogen Inlet' port until a loud click is heard, which indicates that an airtight connection has been established. To release the connector, grab the connector with one hand and the generator with the other. Push the ring on the connector towards the generator, and then unplug the connector from the 'Hydrogen Inlet' port.

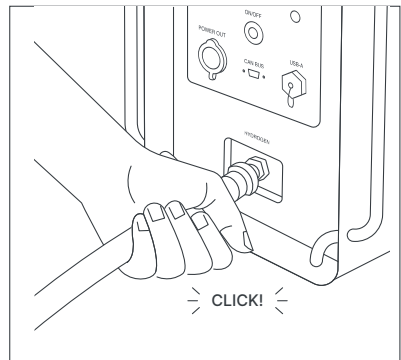

3. Open the manual valve on the regulator.

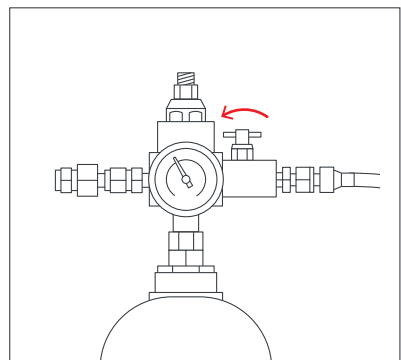

4. The regulator assembly has two gauges – one shows the pressure upstream of the regulator (= inside the cylinder) and the other one downstream of the regulator (= going into the generator). Check that the downstream pressure is between 0.36 and 0.56 barg. If it is not, adjust it by rotating the pin on top of the regulator very slowly.

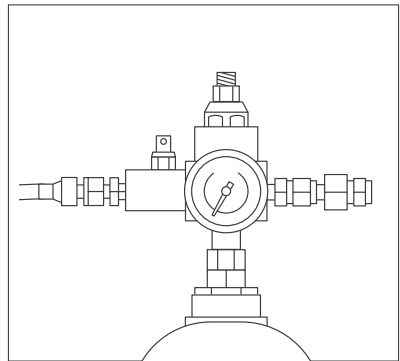
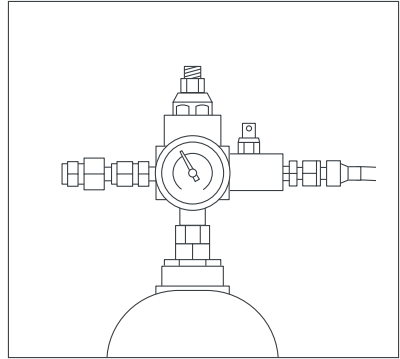

## 3.5 Electrical connection

### 3.5.1 Generator mode

1. Select generator mode in the menu.
2. Check provided cables for damage.
3. Connect open ends of DC output cable to your load.
4. Plug DC output cable directly into the 'DC Out' port of the generator.

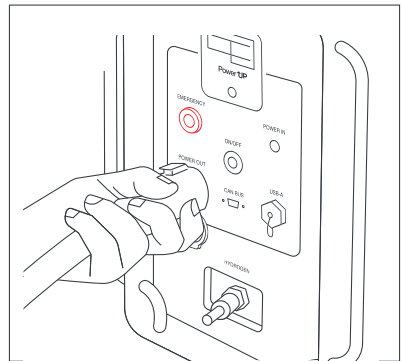
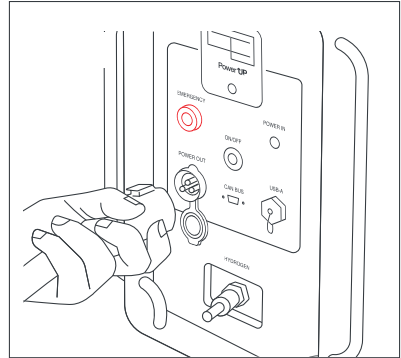



## 3.5.2 Battery Charging Mode

1. Select battery charger mode in the menu.
2. Check provided cables for damage.
3. Connect open ends of DC output cable to your load.
4. Plug DC output cable into the 'DC Out' port of the generator.
5. The generator will automatically detect the parameters of the battery and begin to charge it, as it has a built-in battery charging module.

## 3.5.3 USB Charging Mode

Plug a USB type A cable into the generator's USB port.

### **NB!**

- Only insulated wires should be used.
- Use the cable assembly supplied with the generator to make a reliable connection and connect the unit.
- The circuit connecting the battery must contain a fuse. Alternatively, use the fuse (available as optional equipment) to connect the battery.
- Check the polarity (see illustration) before connecting the unit. Both sensor and power lines must always be connected.
- Always use separate lines for charging (power) and for voltage metering (sensor) to the battery. Otherwise, the current flow will cause false readings.

# 4. Operations

## 4.1 Operating modes

<b>Mode</b>	<b>Description</b>
<b><i>Initializing</i></b>	After being turned on, the generator checks the condition of all its components, hydrogen supply and internal electrical connection.
<b><i>Warmup</i></b>	The generator preconditions the fuel cell stack to be able to output rated power.
<b><i>Ready</i></b>	The generator is ready.
<b><i>Idle</i></b>	The generator is not receiving any hydrogen fuel (ER8), therefore it is idling.
<b><i>Sleep</i></b>	The fuel cell stack is disconnected, but the control circuit of the generator remains on.
<b><i>Shut down</i></b>	The generator is shutting down by disconnecting all loads, followed by cooling the fuel cell stack.

## 4.2 Switching on

1. To turn on the generator, press **ON/OFF**.
2. The display and cooling fans will switch on.
3. Wait 30 to 120 s before using the unit. Once the generator is ready, the interface will show “Ready mode.”

## 4.3 Switching off

1. To turn off the generator, press the power button. Once the power button is pressed, the generator will go into “Shutdown Mode.”

During “Shutdown Mode,” the cooling fans will turn on, cooling the fuel cell stack down quickly.

2. Once the fuel cell stack of the generator has cooled for up to 180 seconds, the generator will turn off on its own.

## 4.4 Hydrogen cylinder replacement

Each cylinder comes with a self-closing valve installed on top of it. The regulator is connected to a self-closing valve. To remove the regulator from the self-closing valve:

1. Turn the large brass nut connected clockwise.  
*This will disconnect the regulator from the self-closing valve and cylinder.*
2. Attach the regulator to a new cylinder (refer to clause 3.3. Of this manual).

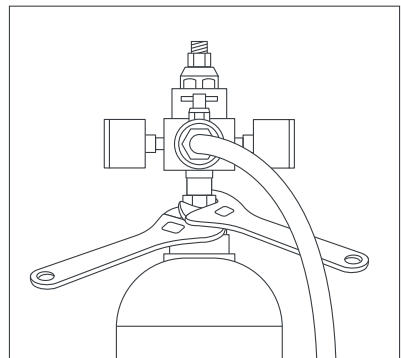

## **NB!**

- **A small amount of dirt may lodge in the regulator which might cause it to malfunction. Inspect the regulator thoroughly and clean carefully if necessary!**
- **Smoking near the cylinders is strictly prohibited!**
- **Changing the cylinders near open fire is strictly prohibited!**

## 4.5 Hydrogen cylinder refilling

The tank must always be filled by suitably qualified persons who are simultaneously confident that neither the cylinder nor the valve body contain any oxidizing gas. Oxidized gas will have a negative effect on the lifetime of your UP generator.

Since we offer different and individual hydrogen storage solutions for every customer, please refer to the specific manual delivered with the hydrogen cylinder you have purchased for more information regarding filling, cleaning and further maintenance instructions.

During the filling and emptying process, the liner may make a noise that is often called a “crunch,” but this is nothing to worry about.

# 5. Maintenance

## 5.1 Filters replacement

Your generator comes with two filters that can be changed when they get clogged. The following rules outline when these filters must be changed:

- Filters must be changed after every 6 months or 2000 hours of operation in dry environments; whichever comes sooner.
- Filters must be changed after every 3 months or 1000 hours of operation in wet environments; whichever comes sooner.

Please contact PowerUP - [support@powerup-tech.com](mailto:support@powerup-tech.com) for the procurement of replacement filters.

### To replace filters

1. Unscrew all 16 screws on the outer perimeter of the filter, using the M2.5 hex head screwdriver.
2. Remove the side cover.
3. Remove old filter.
4. Place in new filter.
5. Re-install and tighten all 16 screws on the outer perimeter of the side cover.

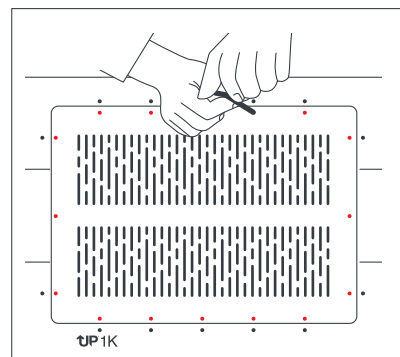
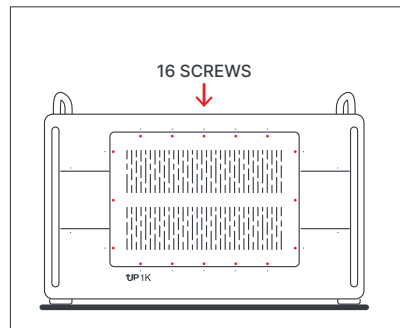

# 6. Troubleshooting

## 6.1 Errors and Troubleshooting

In case of warnings and errors, the error code will appear on the UP series display. Various problems and their solutions are listed in the tables below.

Code	Description	Cause	Effect	Remedy
ER1	Overheating	Internal generator components have overheated to a level that will cause irreversible damage, provided the temperature rise is not stopped immediately.	Generator shuts down.	Allow the generator to cool down prior to turning it on again, for at least 30 mins.
ER2	Oxygen Depletion	Oxygen concentration in the compartment where the generator operates has dropped below 18%.	Generator shuts down.	Make sure the compartment has adequate air ventilation provided before turning on the generator.
ER4	Hydrogen Leakage	Hydrogen concentration inside the generator enclosure has increased to above 1%vol/vol.	Generator shuts down.	Contact PowerUP regarding the servicing of your generator and/or regulator assembly. <b>Do not turn on the generator.</b>

<b>ER8</b>	Insufficient H2 Supply	The generator is not receiving sufficient hydrogen fuel.	Generator does not go into ready mode.	Inspect the connection of the regulator assembly and the 'Hydrogen Inlet' port. Check the regulator assembly and pressure on both gauges.
<b>ER16</b>	Overcurrent	Too much current is drawn from the generator	Generator shuts down.	Ensure that upon re-starting the generator, no load is connected that draws above the nominal power rating of the generators.
<b>ER32</b>	Low Internal Battery	The charge of the internal service battery is critically low.	Generator shuts down.	Prior to turning the generator back on, charge its internal battery (see 6.2).

In some cases, error states can occur in combination, as shown in the table below:

Error Code	Description
ER17	Overcurrent + Overheating
ER20	Overcurrent + Hydrogen Leakage
ER6	Oxygen Depletion + Hydrogen Leakage
ER48	Low Internal Battery + Overcurrent
ER40	Low Internal Battery + Insufficient H2 Supply
ER36	Low Internal Battery + Hydrogen Leakage
ER34	Low Internal Battery + Oxygen Depletion
ER33	Low Internal Battery + Overheated

If a serious problem happens inside of or near the generator that neither the generator nor its firmware can detect, press the **Emergency OFF** button right away until you hear a loud click. This means that the button has been latched.

This will turn off all the power inside the generator right away. Please don't press this button unless it's absolutely necessary, as it will cause some damage to the fuel cell stack.

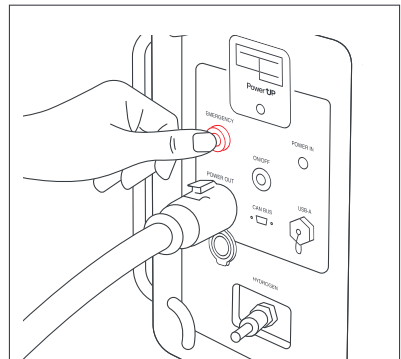



The generator cannot be restarted until the **Emergency OFF** button has been unlatched. Turn the emergency button clockwise to unlatch it.

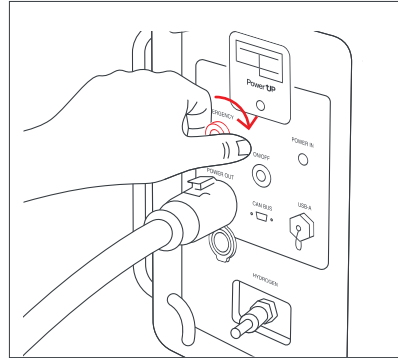

## 6.2 Recharging the internal battery

To recharge the internal battery:

1. Plug the AC end of this charger into your mains supply (make sure that your mains supply conforms to the specifications stated on the charger, and has at least a 16A fuse), and the DC end into the 'DC In' port of the generator.
2. Charge the internal battery for 30 mins.
3. Disconnect the charger, then power on the generator.

**Only use the proprietary charger you received with the generator.**

## 6.3 Support contact

If the issue persists, please contact PowerUP support:  
[support@powerup-tech.com](mailto:support@powerup-tech.com)

# 7. Transportation and storage

## 7.1 Transportation requirements

- To protect the generator from damage, always transport the generator in its original packaging.
- Do not stack generator boxes or place heavy items on top of them.

## 7.2 Storage requirements

- Keep the generator in a cool, dry place.
- Keep away from direct sunlight.
- Refer to clause 2.3 *Specification* for recommended storage temperature and humidity.

**NB!** Generator has an internal battery that can run flat if the generator is stored for a long period of time, therefore it is recommended to run the generator every 12 months for 1+ hour.

# 8. End of life and disposal

Dispose of the packaging in an environmentally responsible way in accordance with the local regulations.

To recycle old fuel cell generators, please contact our support line:  
**[support@powerup-tech.com](mailto:support@powerup-tech.com)**

**PowerUP Energy Technologies**  
Akadeemia tee 23,  
12618 Tallinn, Estonia

+372 503 6963  
info@powerup-tech.com  
powerup-tech.com